

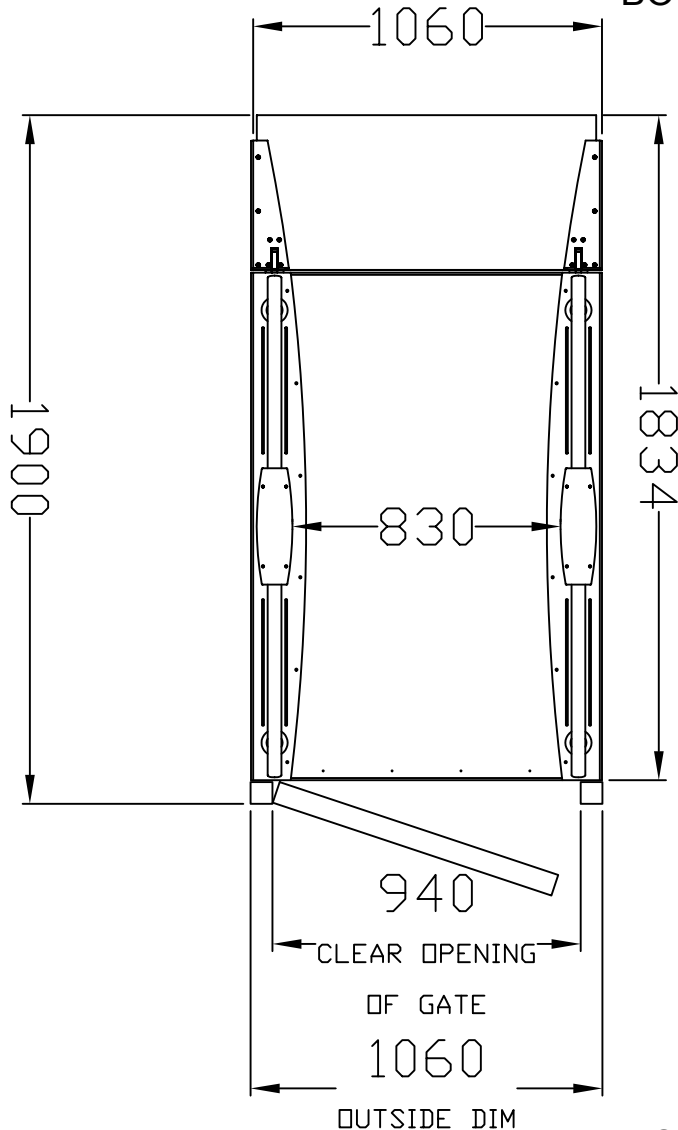

BOTTOM SIDE



**Recommend 1000mm
clear depth in front of
ramp**

**This layout drawing
is for guidance only.
Please contact our
trained and experi-
enced lift designers
to ensure your com-
plete understanding
of your lift require-
ments.
We look forward to
your call.**

**Minimum side clearances
100mm on each side**

NOT FOR CONSTRUCTION

**Recommend 1000mm
clear depth in front of
gate**

TOP SIDE

**P1
830 x 1400**

CONSTRUCTION DETAILS

- Construction Material site specific
- External shaft size 1060 (w) X 1900 (d)
- Running clearance 100mm required to each side
- Pit depth not required
- Headroom 2000mm recommended
- Machine cabinet 410 (h) x 410 (d) x 460 (w)
up to 6m away from platform
- Power supply single phase, 240v

SHOWROOMS

NSW: 1 / 75 Corish Circle Eastgardens, 2036
T: (02) 9666 3939
F: (02) 9666 3949

VIC: 1/1 Belgium Ave Richmond, 3121
T: (03) 9421 4222
F: (03) 9421 4333

Toll Free: 1800 440 714
www.liftshop.com.au

STANDARD SPECIFICATIONS

- Person capacity 250kg (1-2 persons)
- Speed 0.10 m/s
- Maximum Travel 1000mm
- Safety Protection bellows safety apron
- Maximum floors 2
- Compliance AS1735.14
- Cabin fit out options available
- Doors finishes options available