



NOT FOR CONSTRUCTION

This layout drawing is for guidance only. Please contact our trained and experienced lift designers to ensure your complete understanding of your lift requirements. We look forward to your call.

BOTTOM SIDE

Recommend 1000mm clear depth in front of ramp

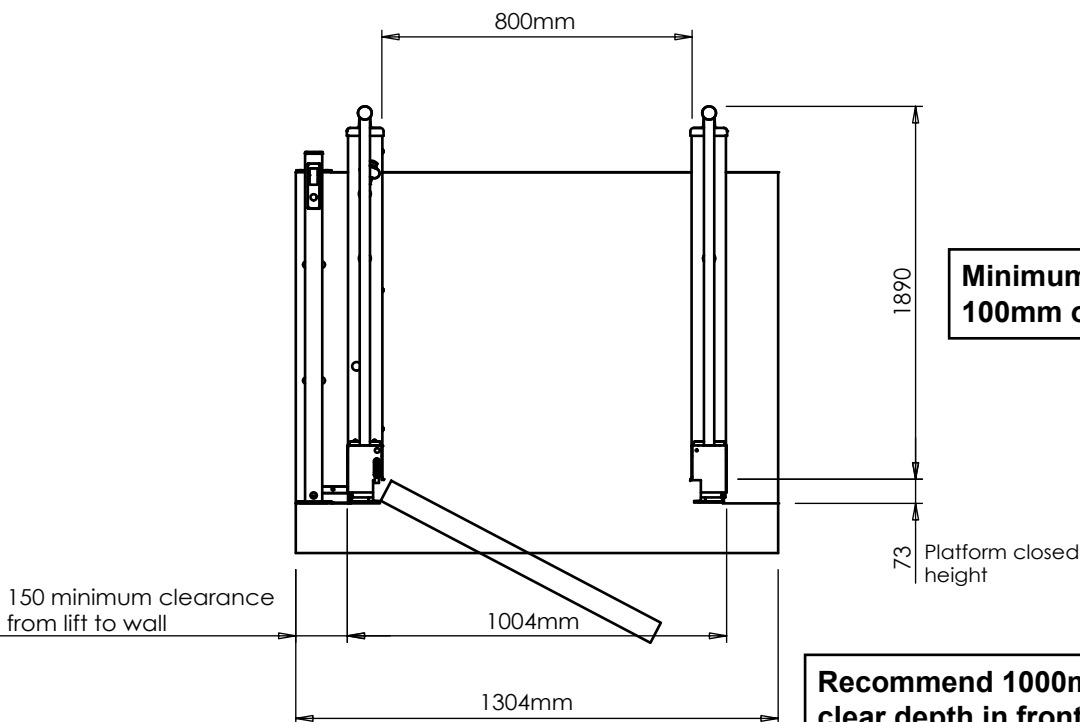

Minimum side clearances 100mm on each side

Recommend 1000mm clear depth in front of gate

TOP SIDE

P1-S
800 x 1450

CONSTRUCTION DETAILS	
• Construction Material	site specific
• External shaft size	1304 (w) X 1890 (d)
• Running clearance	100mm required to each side
• Pit depth	not required
• Headroom	2000mm recommended
• Motor	Internally fixed
• Power supply	single phase, 240v

SHOWROOMS

NSW: 1 / 75 Corish Circle Eastgardens, 2036 T: (02) 9666 3939 F: (02) 9666 3949	VIC: 1/1 Belgium Ave Richmond, 3121 T: (03) 9421 4222 F: (03) 9421 4333
--	--

Toll Free: 1800 440 714
www.liftshop.com.au

STANDARD SPECIFICATIONS	
• Person capacity	300kg (1-2 persons)
• Speed	0.15 mm/s
• Maximum Travel	1000mm
• Safety Protection	bellows safety apron
• Maximum floors	2
• Compliance	AS1735.14